

Table of contents



Foreword.....	1
Safety instructions	2-6
Intended use.....	6
Operating instructions	7
Technical data	7
Device description	7-8
Installation instructions	9
Before commissioning.....	9
Commissioning	10-12
Hose drainage	13
Recommendations for drying with the Comedes Demecto 12.....	14-15
Maintenance	16-18
Frequently Asked Questions.....	18-19

Dear Customer,

Thank you for choosing the Demecto 12 from Comedes GmbH.

You have purchased a powerful dehumidifier that has been developed according to the latest technical standards. To ensure that the appliance will be a faithful helper for you over a long period of time, we ask you to study the operating instructions in detail, especially the safety instructions.

If you still have questions about the unit after reading the operating instructions, please do not hesitate to contact us:

E-mail address: service@comedes.com

If you give us your phone number, we will call you back free of charge.

We welcome any feedback from customers and welcome you to contact us.

With kind regards

Philipp Thannhuber
Managing Director

Comedes GmbH

WARNING:

Read the instructions carefully before commissioning. Failure to comply with the safety information and instructions may result in electric shock, fire and/or serious injury. Keep these instructions and all safety notes and instructions for future reference.

Caution! Do not open the unit until the mains plug has been removed from the mains socket. Danger to life due to electric shock! Have repairs carried out only by an authorised specialist workshop.



Only install the unit in rooms with an area of more than 6m².
Do not install the appliance in a place where flammable gas may escape.

The dehumidifier is used to remove excess moisture from the air. The resulting reduction in relative humidity protects buildings and their contents from the adverse effects of excessive humidity.

The refrigerant used is the environmentally friendly R290. R290 has no harmful effect on the ozone layer (ODP), a negligible greenhouse effect (GWP) and is available worldwide. Due to its efficient energy properties, R290 is an excellent refrigerant for this application. Due to the high flammability of the coolant, special precautions must be taken.

Symbols



warning

Danger due to flammable gas

This symbol alerts you to dangers to health and life from extremely flammable gas. If refrigerant escapes and comes into contact with a fire or a heating element, harmful gases are produced and there is a risk of fire.



Observe operating instructions

This symbol indicates that you should read the operating instructions before installing and operating the appliance.



Observe the operating instructions and operating notes

This symbol draws your attention to the need to observe and comply with the operating instructions and the operating instructions contained therein.



Observe repair instructions, technical manual

Activities on the refrigeration circuit, such as disposal, repairs and maintenance activities, may only be carried out by persons with a relevant certificate of competence and only in accordance with the manufacturer's instructions. Repair instructions as well as maintenance and disposal information are available from the manufacturer on request.



Danger

There is danger to the unit or objects in the vicinity of the unit.



Electrical hazard

Danger of electric shock

Safety instructions

Do not use any agents other than those recommended by the manufacturer to speed up the defrosting process or to clean the dehumidifier.

The appliance must be stored in a room without



caution, risk of fire

continuously operating ignition sources (e.g. open flames, a gas appliance switched on or an electric heater switched on).



caution, risk of fire

Do not disassemble, pierce or burn the appliance, even after use.



Use the on/off switch to turn the unit on and off. Never use the plug to switch the unit on and off.

The appliance may only be installed, operated and stored in a room with a floor area of more than 6m².



Maintenance must only be carried out in accordance with the manufacturer's instructions. The unit must be disconnected from the power supply during maintenance. The unit must be stored in a well-ventilated area where the room size corresponds to the room size specified for operation.



caution, risk of fire

All work processes that affect safety-relevant aspects (e.g. repairs) may only be carried out by qualified personnel.



Do not immerse the unit in water or other liquids and do

not expose it to rain, moisture or other liquids.

If the mains cable is damaged, it must be replaced by the manufacturer, its service partner or similarly qualified persons in order to avoid a hazard.



Please contact a professional to have the product repaired. Improper repairs may result in injury to the user.

Disconnect the appliance from the power supply before moving, cleaning or servicing it and also when it is not in use or in case of malfunctions. Never pull on the power cord.

Observe the national installation regulations and only connect the unit to a properly installed **protective contact socket** with a mains voltage/frequency/power according to the type plate. Do not place any objects on the dehumidifier.

Do not climb or sit on the unit.

Do not unplug the unit by pulling the mains cable.

Always grasp the mains plug for this purpose.

Do not tilt or overturn the unit. This may cause water leakage and damage the appliance.

This appliance can be used by children aged from 8 years and above and persons with reduced physical, sensory or

mental capabilities or lack of experience and knowledge if they have been given supervision and/or instruction concerning use of the appliance in a safe way and understand the hazards involved. Children must not play with the appliance. Cleaning and maintenance must not be carried out by children without supervision. Do not place the unit directly against a wall or under a wall cabinet or similar. The unit requires a free space of at least 30 cm at the top and on all sides.



The unit is to be used only in the temperature range between 5°C and 35°C.

Do not use the unit in a wet area. The unit is not splash-proof.

Position the unit on a flat, stable, non-slip, hard and dry surface. This is to avoid increased noise, vibration, water leakage or electric shock.



Never insert your fingers or other objects into the unit. This can cause damage to the of the unit.

Do not touch the air inlet or the aluminium fins of the unit.

Unplug the unit after you have switched it off or do not intend to use it for a long period of time or when you want to clean it.



The working area of the unit must be at least 6m². It must be ensured that there are no flammable materials in the working area of the unit.

Do not clean the dehumidifier with water or chemicals.

Prevent water from getting on/near the unit.

Do not spray the unit with flammable liquids or cleaning agents.

Do not touch the ventilation slots.

Keep the air inlet and outlet clear of obstructions.

Keep all necessary ventilation openings free of obstructions.

Do not use the appliance if the mains lead is damaged.

Do not use the unit in hermetically sealed rooms.



Keep the water tank free of foreign objects.

Place the unit away from heaters or heat-generating appliances.

The unit must not be used in environments with a high dust or chlorine content.

Only use the appliance if your socket outlet is equipped with an RCD (ground fault circuit interrupter).

Do not operate/touch the unit with wet hands. Prevent water from splashing onto the appliance.

Do not attempt to carry out repairs or other adjustments to the unit yourself.

Do not let children play with



the packaging, such as plastic film.

Ensure that the dehumidifier is positioned away from fire, flammable, corrosive and explosive materials.

Insert the mains plug firmly and securely into the socket.

Do not operate the dehumidifier via a multiple socket, plug adapter or extension cord.

Do not operate the unit if it has been dropped, damaged or shows signs of malfunction.

Do not operate the unit in the immediate vicinity of walls, curtains or other objects that may block the air inlet and outlet.

If the unit has been tilted more than 45°, let it stand upright for at least 24 hours before using it.

Do not operate or store the unit in direct sunlight or in the rain.

Never place the mains cable or the appliance on hot surfaces or near sources of heat.



Lay the mains cable so that it does not come into contact with hot or sharp-edged objects.

Do not bend the mains cable or wrap it around the unit as this may cause the cable to break.



Please note that in addition to switching off the unit, you must also pull the mains plug

out of the protective contact socket to completely disconnect the unit from the mains.

No naked flames, cigarettes or other possible sources of ignition shall be used inside or near the equipment.



Transport, storage and disposal

When transporting units and parts containing flammable refrigerants, the transport regulations must be observed.

The disposal of appliances with flammable refrigerants must be carried out in compliance with national regulations.

The maximum number of units that may be stored together depends on local regulations

The unit must be stored in such a way that no mechanical damage can occur.

Empty the water tank before moving the appliance to avoid water leakage.

Notes on the refrigerant R290

The unit is only designed for use with R-290(propane) gas as refrigerant.

The refrigerant circuit is sealed. Maintenance work in this regard may only be carried out by a qualified technician. The maintenance manual must

be requested by the technician from the manufacturer.

Do not discharge the refrigerant into the atmosphere.

R290 (propane) is extremely flammable and heavier than air. It first accumulates in low areas, but can be circulated by fans.

If propane gas is present, or the presence is suspected, do not allow untrained persons to search for the cause.

The propane gas used in this appliance is odourless.



Therefore, gas may have leaked even without a noticeable odour.

The components used are designed for propane gas and are therefore not ignitable and spark-free. Components may only be replaced by identical spare parts approved by the manufacturer.

Note that the refrigerant is odourless.

Compliance with national gas regulations must be observed.

Failure to comply with the safety instructions may result in an explosion, death, injury and property damage.

 Attention	Any person carrying out work on the refrigerant circuit must hold a current valid certificate of competence from an industry accredited assessment body demonstrating their competence to handle refrigerants safely in accordance with an industry approved procedure.
 Attention	Maintenance must only be carried out in accordance with the manufacturer's instructions. During maintenance and repairs that require the assistance of other skilled personnel, the person trained in handling flammable gases must constantly supervise the work.

If you do not understand something or need help, please contact the manufacturer. You will find the contact details at the end of these operating instructions.

Intended use

The dehumidifier is only intended for dehumidifying privately used indoor rooms (e.g. for living rooms, bedrooms, storage rooms or cellars). The unit is not suitable for outdoor use. The user must comply with the specified operating parameters of these instructions.

The machine may only be used in accordance with its intended purpose. Any other use beyond this is not in accordance with the intended use. The user/operator, and not the manufacturer, is liable for any damage or injury of any kind resulting from such use.

Operating instructions

The unit is designed for a temperature range between 5 and 35°C. Below 5°C the humidity tends to be very low, so you do not need to use a dehumidifier. Above 35°C, the overheating protection may automatically switch off the unit. The unit is not approved for operation outside the temperature range.

In order for the dehumidifier to dehumidify optimally, it warms the air. Therefore, the room temperature may rise by 1-2 degrees. This is quite normal and increases the efficiency of the unit.

When the water tank is full, the machine switches off automatically.

To protect the compressor, it has a switching delay of 3 minutes. Wait 3 minutes until the dehumidifier resumes dehumidification.

Technical data

Product name:	Comedes Demecto 12
Voltage:	AC220-240V/50 Hz
Rated power:	200W
(30°C 80% humidity)	
Current consumption:	1,2 A
(30°C 80% humidity)	
Max. suction/pressure side	
Operating pressure:	0.7MPa / 3.2MPa
Dehumidification capacity:	12 l/ day (30°C 80% humidity)
Weight:	10.0 kg
Permissible operating temperature:	5-35°C
Refrigerant / Amount:	R290/50g
Water tank size:	2,0 l
Noise emission:	≤ 38 dB(A)
Dimensions:	255x220x445 mm
Air flow rate fan stage 1:	100m ³ /h
Air flow rate fan stage 2:	120m ³ /h

Device description

Figure 1:

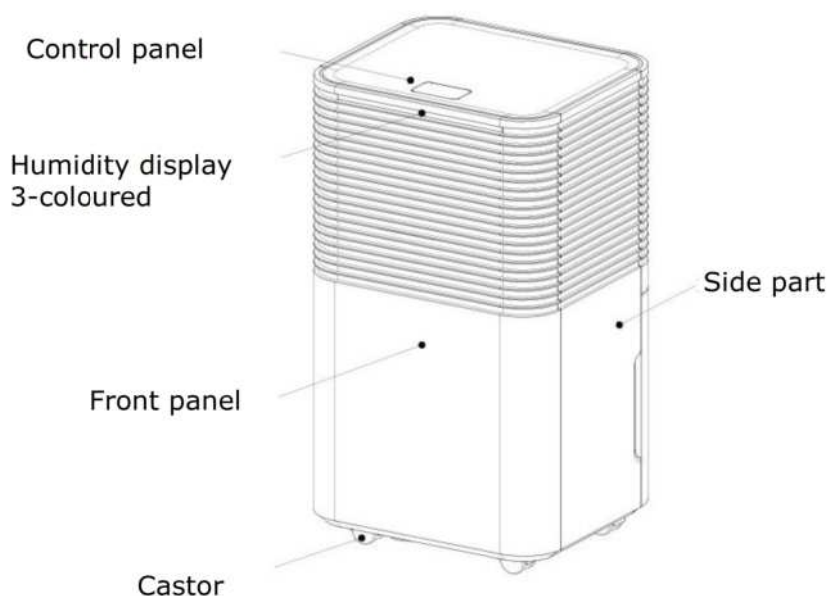
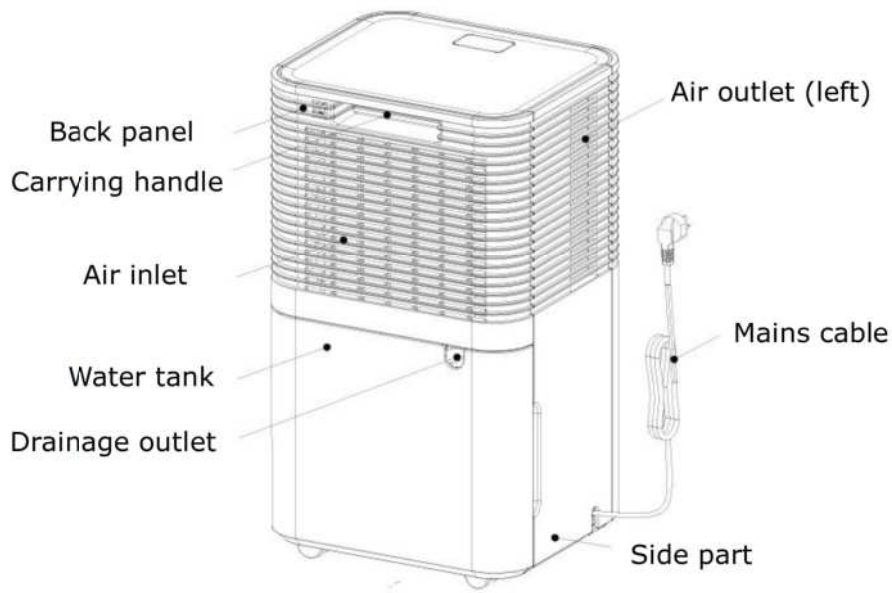
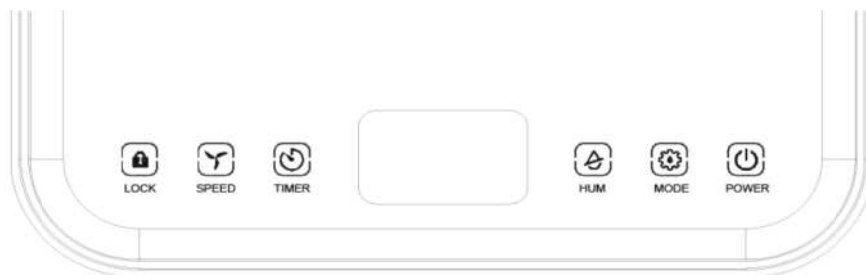

Figure 2:



Control panel

Figure 3:



Display

Figure 4:

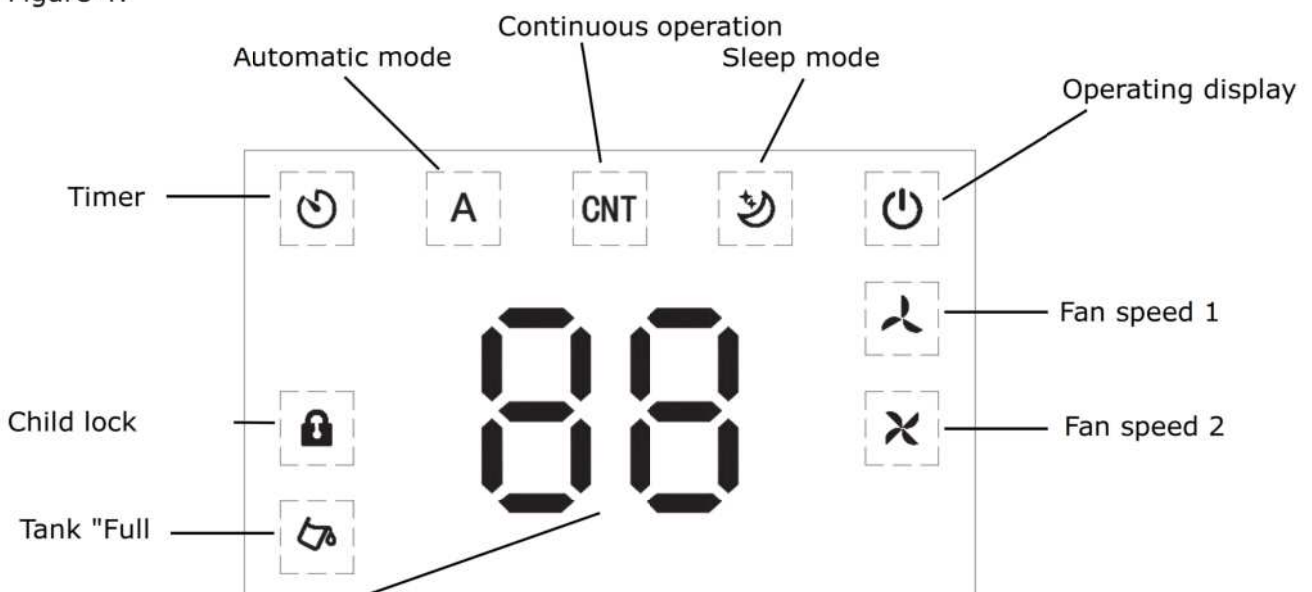

Display indication:

The illuminated display shows the prevailing room humidity as soon as the unit is plugged in. During the setting of the timer and the target humidity, the selected values are displayed. After the setting is finished, the current room humidity is displayed again.

Installation instructions



**Only operate the appliance in rooms with at least 6m².
Floor space**

- Remove all adhesive tapes that were used to secure the unit for transport.
- Keep doors and windows closed to save more energy. Check that the appliance is standing securely on firm, level and dry ground.
- Never install the unit where it may be exposed to the following conditions:
 - Heat sources such as radiators, heat registers, stoves or other products that generate heat.
 - In an area where oil or water may be splashed.
 - Direct sunlight
 - Mechanical vibrations or shocks
 - Excessive dust exposure
 - Lack of ventilation, e.g. in the cupboard or bookshelf
 - Uneven surface
- Make sure that the socket outlet is equipped with an RCD circuit breaker (ground fault circuit interrupter). If you are not sure whether this is the case, you can ask your electrician or use a personal protection plug (available in DIY stores).



- To save power and avoid potential hazards, unplug the unit when not in use.
- Keep at least 30cm distance around the unit from walls and objects. Make sure that the air outlet is clear and that there are no curtains or textiles above it.

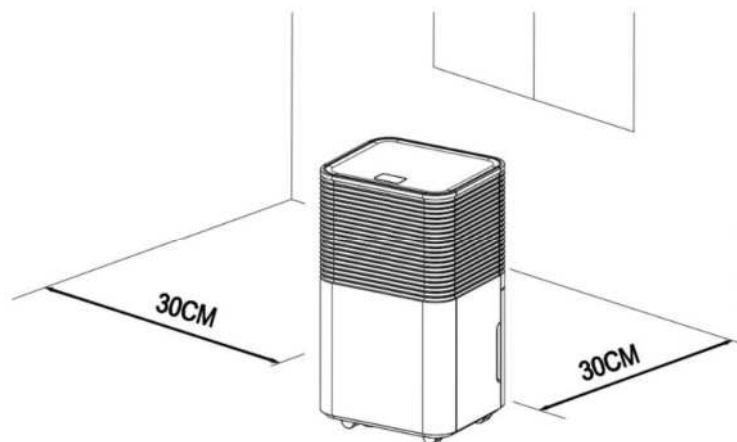

Before commissioning

After unpacking the unit, check it for completeness and possible transport damage to avoid hazards. If in doubt, do not use it, but contact our customer service. The service address can be found at the end of this manual. Please read the operating instructions carefully before using your dehumidifier for the first time.

Your unit is packaged to protect it from damage during transport.

- Carefully remove the unit from its sales packaging.
- Remove all packaging parts.
- Clean the unit and all accessories from packaging dust residues, according to the instructions in the chapter "Maintenance".
- Leave the unit in the final position for at least 24 hours before commissioning.

Commissioning

Before plugging in the mains plug, check the unit and especially the cable for damage. The unit may only be operated with a faultless mains cable.

Plug in the mains cable and switch on the unit with the on/off switch.

CAUTION: Always allow the unit to run for at least 35 minutes before switching it off and never switch the unit off and on continuously. There is a risk of compressor damage.

After switching off the Comedes Demecto 12, leave it to stand for at least 3 minutes without moving the appliance so that the water in the drip tray can drain off completely.

The higher the humidity in a room and the higher the temperature in it, the better the Comedes Demecto 12 can dehumidify the air. Therefore, the compressor will generate heat and thus warm up the room air. This is quite normal and need not worry you.

Note: Before using the unit for the first time, we recommend that you operate it with the window open for 5-10 minutes to remove any residues that may be present due to production. Any odour that may occur is normal and disappears after a short time. This is not a malfunction of the unit. Ensure that there is sufficient ventilation.



On / Off switch:

When you plug in the unit, a beep sounds and all indicators light up for 1 second, then only the "POWER" indicator lights up.

Press the On / Off switch to turn the unit on; the dehumidifier starts in automatic mode with a target humidity of 60%RH and high air flow.

Press the on/off switch again to switch the unit off. The compressor switches off immediately and the fan switches off with a delay of 30 seconds.



Operating modes

By pressing this button repeatedly, you can choose between 3 operating modes.

1 Laundry drying / continuous operation

The dehumidifier dehumidifies with a high air flow rate until it is switched off or the water tank is full. In this mode, no target humidity can be set and the fan speed cannot be changed.

When the unit is switched off, the setting is saved. When it is switched on again, the dehumidifier restarts in this setting.

2 Automatic mode

If the humidity is $\geq +3\%$ than the set value, the fan starts working and the compressor starts after 3 seconds.

If the humidity is $\leq -3\%$ than the set value, the compressor switches off and the fan switches off with a delay.

Both the fan speed and the humidity can be set in automatic mode.

When the unit is switched off, the setting is saved. When it is switched on again, the dehumidifier restarts in this setting.

3 Sleep mode

If no further button touches are made within 10 seconds of selecting sleep mode, all displays gradually go dark and the fan speed is automatically switched from high to low. Touch any button to reactivate the display illumination. Press the "Mode" key again to exit sleep mode.

In sleep mode, the fan speed cannot be changed and error codes are not displayed. Setting a target humidity is possible in sleep mode.



Humidity setting:

The unit is equipped with a modern hygrostat (humidity controller) and switches off automatically after reaching the desired humidity in order to save energy. The compressor switches off first and then the fan 30 seconds later. When the humidity in the room rises again, the Comedes Demecto 12 switches on automatically.

By repeatedly pressing the button, the target humidity can be set between 30% and 80% in 5% steps.

The set target humidity is now shown on the display for approx. 5 seconds.

To have the current room temperature shown on the display, press and hold this button until the room temperature is shown. After approx. 5 seconds, the display shows the current room humidity again.

The dehumidifier starts dehumidifying when the room humidity is at least 3% higher than the set target humidity.



Timer:

Press the timer button to start the timer function. By pressing repeatedly, you can set a time of 1-24 hours in 1 hour steps. If the timer is activated, this is indicated by the corresponding symbol on the display.

If you activate the timer during operation, the appliance switches off after the set time.

If you activate the timer while the unit is in standby mode, the unit will start automatically after the set time has elapsed.

To switch off the timer, press the button repeatedly until "00" is displayed.



Speed:

Press this button to switch between the two fan speeds.

The currently selected fan speed is shown on the display.



Child safety lock:

Press and hold this button to activate the child lock. No more settings can be made. If the child lock is active, this is indicated by the corresponding symbol on the display. Press and hold this button again to deactivate the child lock. When the unit is restarted after a power failure or similar, the child lock is always deactivated.

3-colour humidity display

Blue: Humidity <45%

Green: Humidity $45\% \leq RH \leq 65\%$

Red: Humidity >65%

If an error or status message appears on the display, the humidity indicator lights up red.

Empty the water tank:

When the water tank is full, the Comedes Demecto 12 switches off automatically and the tank "full" indicator on the display lights up. This is also signalled acoustically. You must empty the water tank to be able to put the Demecto 12 back into operation. To do this, always switch off the unit first and disconnect the mains plug.

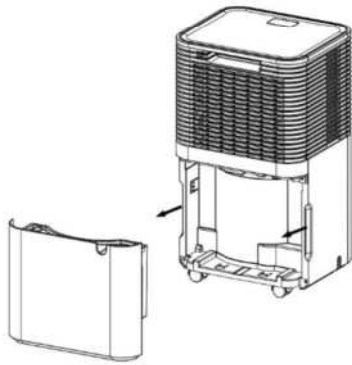

Grasp the water tank by the two recesses on the side and carefully pull it backwards out of the appliance.

Caution: To avoid spilling water, it is recommended to hold the water tank with both hands when removing and transporting it.

Now empty the water tank completely into a wash basin or similar. If necessary, clean the inside and outside of the tank.

Carefully reinsert the tank after it has been completely emptied. To do this, grasp the water tank on both sides and push it straight into the appliance.

Make sure that the tank is correctly inserted to ensure proper operation of the appliance.

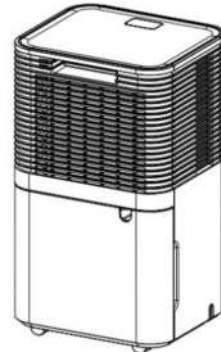

Attention:

- To ensure correct and safe operation of the appliance, the float and its locking device must not be removed from the water tank. Otherwise, this may cause the water tank to overflow.

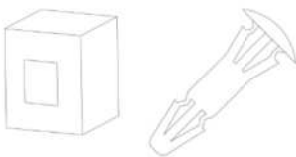

- If the water tank is dirty, it should be cleaned. Use cold or warm water without additives. Additives or cleaning utensils such as washing-up liquid, steel wool, benzene or other chemical cleaners are not suitable as they can damage the tank and cause leakage.

Hose drainage

The Comedes Demecto 12 can also be operated using a drainage hose (Ø9.0mm). To do this, remove the water tank and attach a drainage hose.

To do this, proceed as follows:

1. Remove the water tank

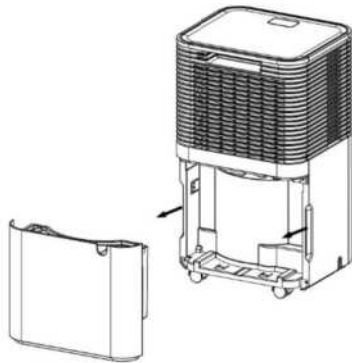

2. Attach the drainage hose to the drain of the drip tray.

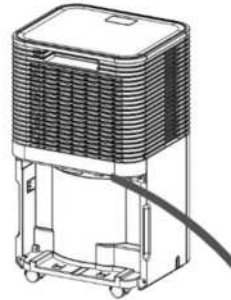

3. Put the water tank back in place, and guide the hose through it the recess of the drainage outlet.

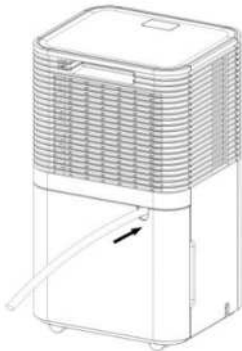

Attention:

- Make sure that the hose does not run higher than the hose connection on the appliance at any point so that the water can drain off undisturbed.
- Make sure that the drainage hose is not kinked or blocked. Check this regularly.
- Make sure that the end of the hose is not below the water surface of the drain or similar.

The appliance must be switched off and disconnected from the mains after each use and before attaching or removing accessories by pulling the mains plug out of the protective contact socket after switching off. Let the appliance cool down to room temperature before cleaning and/or storing it.

Automatic defrost

The dehumidifier is equipped with a temperature-dependent defrost function.

At a room temperature between 5°C and 16°C, the unit starts defrosting every 45 minutes. During the defrosting process, the power LED flashes.

Recommendations for drying with the Comedes Demecto 12

In order to achieve the best possible dehumidification result with the Demecto 12 with the lowest possible

To achieve the best possible energy efficiency, we provide the following information:

As this manual can only provide limited help, we recommend that you obtain further information at: www.comedes.com.

Basics of dehumidification with the Comedes Demecto 12

The dehumidifier works similarly to a refrigerator with a refrigerating machine. This creates a cold surface (at the evaporator) on which water condenses. Depending on the humidity and ambient temperature, the water condenses at the dew point temperature. In order for the dehumidifier to dehumidify, the cold surface must be below the dew point temperature. Since the water would freeze at negative dew point temperatures, the dehumidifier can only work with positive dew point temperatures. To ensure this, the dehumidifier is equipped with a modern, temperature-controlled automatic defrosting system that keeps the evaporator temperature approximately between 0 and 5°C. In order to be able to dehumidify sensibly, the dew point temperature should be above 5°C. If the dew point temperature is below this, dehumidification is either not possible at all or only very inefficient. You can use the following table to determine the dew point temperature in your case.

If the dew point temperature is too low, it is advisable to heat.

Attention:

Only heat the room with water-bearing heating units, such as underfloor heating and permanently installed radiators.

If this is not possible, the room can be preheated with another electrical heater. However, the dehumidifier must not be in this room.

The safety and operating instructions in this manual must be followed under all circumstances.

Temp. in °C	RH in %															
	20%	25%	30%	35%	40%	45%	50%	55%	60%	65%	70%	75%	80%	85%	90%	95%
30°C	4.6	7.8	10.5	12.9	14.9	16.8	18.4	20	21.4	22.7	23.9	25.1	26.2	27.2	28.2	29.1
29°C	3.8	7.2	9.7	12	14	15.9	17.5	19	20.4	21.7	23	24.1	25.2	26.2	27.2	28.1
28°C	3	6.1	8.6	10.8	13.1	15	16.6	18.1	19.5	20.8	22	23.2	24.2	25.2	26.2	27.1
27°C	2.1	5.3	8	10.2	12.2	14.1	15.7	17.2	18.6	19.9	21.1	22.2	23.3	24.3	25.2	26.1
26°C	1.3	4.5	7.1	9.4	11.4	13.2	14.8	16.3	17.6	18.9	20.1	21.2	22.3	23.3	24.2	25.1
25°C	0.5	3.6	6.2	8.5	10.5	12.2	13.9	15.3	16.7	18	19.1	20.2	21.3	22.3	23.2	24.1
24°C	-0.3	2.8	5.4	7.6	9.6	11.3	12.9	14.4	15.8	17	18.2	19.3	20.3	21.3	22.3	23.1
23°C	-1.1	1.9	4.5	6.7	8.7	10.4	12	13.5	14.8	16.1	17.2	18.3	19.4	20.3	21.3	22.2
22°C	-2	1.1	3.6	5.9	7.8	9.5	11.1	12.5	13.9	15.1	16.3	17.4	18.4	19.4	20.3	21.2
21°C	-2.8	0.2	2.8	5	6.9	8.6	10.2	11.6	12.9	14.2	15.3	16.4	17.4	18.4	19.3	20.2
20°C	-3.6	-0.3	1.9	4.1	6	7.7	9.3	10.7	12	13.2	14.4	15.4	16.4	17.4	18.3	19.2
19°C	-4.4	-1.4	1	3.2	5.1	6.8	8.3	9.8	11.1	12.3	13.4	14.5	15.5	16.4	17.3	18.2
18°C	-5.2	-2.2	0.2	2.3	4.2	5.9	7.4	8.8	10.1	11.3	12.5	13.5	14.5	15.4	16.3	17.2
17°C	-6.1	-3.1	-0.6	1.4	3.3	5	6.5	7.9	9.2	10.4	11.5	12.5	13.5	14.5	15.3	16.2
16°C	-6.9	-4	-1.4	0.5	2.4	4.1	5.6	7	8.2	9.4	10.5	11.6	12.6	13.5	14.4	15.2
15°C	-7.7	-4.8	-2.2	-0.3	1.5	3.2	4.7	6.1	7.3	8.5	9.6	10.6	11.6	12.5	13.4	14.2
14°C	-8.6	-5.7	-2.8	-1	0.6	2.3	3.7	5.1	6.4	7.5	8.6	9.6	10.6	11.5	12.4	13.2
13°C	-9.4	-6.5	-3.7	-1.9	-0.1	1.3	2.8	4.2	5.5	6.6	7.7	8.7	9.6	10.5	11.4	12.2
12°C	-10.2	-7.4	-4.5	-2.6	-1	0.4	1.9	3.2	4.5	5.7	6.7	7.7	8.7	9.6	10.4	11.2
11°C	-11.1	-8.2	-5.2	-3.4	-1.8	-0.4	1	2.3	3.5	4.7	5.8	6.7	7.7	8.6	9.4	10.2
10°C	-11.9	-9.1	-6	-4.2	-2.6	-1.2	0.1	1.4	2.6	3.7	4.8	5.8	6.7	7.6	8.4	9.2
9°C	-12.6	-9.8	-6.6	-4.6	-2.8	-1.2	-0.1	0.67	1.8	2.93	3.92	4.77	5.65	6.48	7.23	
8°C	-13.2	-10.5	-7.2	-5.2	-3.4	-1.8	-0.27	-1.1	-1.05	-0.08	0.85	1.86	2.72	3.42	4.09	4.78
7°C	-13.9	-11.2	-7.8	-5.8	-4	-2.4	-1.05	-0.29	-1.51	-1.79	-0.88	-0.09	0.78	1.62	2.44	3.2
6°C	-14.6	-11.9	-8.5	-6.4	-4.6	-2.8	-1.2	-0.4	-1.16	-1.48	-1.17	-0.98	-0.26	0.47	1.2	
5°C	-15.2	-12.6	-9.2	-7.1	-5.2	-3.4	-1.6	-0.8	-1.3	-1.6	-1.3	-1.1	-0.3	0.4	1.1	1.8

Drying for problems with condensation moisture

Condensation moisture usually occurs in cellars when humid air enters the cellar in summer and condenses on the cold cellar walls. We recommend dehumidifying the cellar room by room in continuous operation first. First, let the unit run in continuous operation until you notice that the amount of water you empty from the tank every day is decreasing. Now move the unit to the next room. Once you have dried all the rooms, we recommend selecting a central installation location and operating the unit in automatic mode. This type of dehumidification is more energy-efficient than dehumidifying immediately in automatic mode, as the unit then switches off and on very frequently.

Drying in case of building defects or water damage

In the case of building defects and water damage, the cause should first be eliminated. Afterwards, the rooms can be dried with condensation dryers such as the Demecto 12. In this case, the dehumidifier is operated continuously. The ambient temperature should be at least 20°C (not more than 27°C).

Caution: Only heat the room with water-bearing heating units, such as underfloor heating and permanently installed radiators.

If this is not possible, the room can be preheated with another electrical heater. However, the dehumidifier must not be in this room.

The safety and operating instructions in this manual must be followed under all circumstances. Please note that depending on the construction defect, insulation drying may also be necessary.

can be carried out. This must be carried out by a specialist company.

Recommended humidities for rooms

Basically, this depends on the ambient temperature. The higher the temperature of the room, the lower the relative humidity should be set, otherwise mould growth in the room is promoted. The comfortable humidity ranges from 35% to 65% relative humidity, depending on the ambient temperature.

The following diagram gives an indication of which humidity levels are optimal at which ambient temperatures.

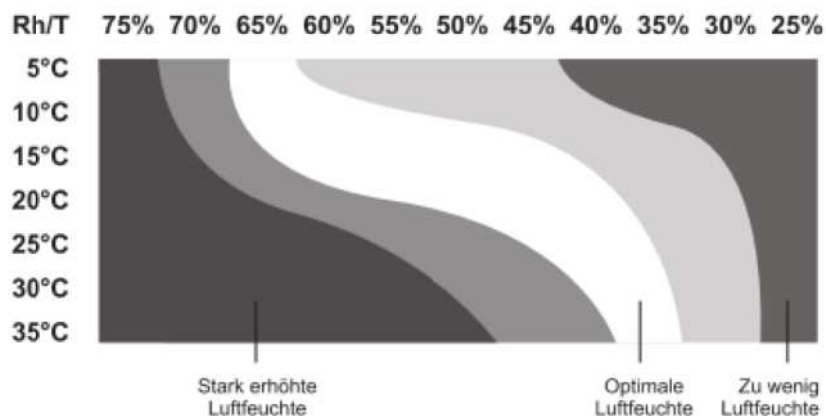

The diagram assumes that temperatures $\geq 20^\circ\text{C}$ are living rooms and temperatures $\leq 20^\circ\text{C}$ are basement rooms.

Maintenance

Always switch off and unplug the appliance before cleaning, maintaining or repairing the appliance.

A maintenance log must be kept for the operation of the unit as follows

Maintenance protocol for Comedes Demecto 12:

Serial number:

Maintenance and care interval	1	2	3	4	5	6	7	8	9	10	11	12	13	14	15
Check air inlet and air outlet and remove impurities.															
Exterior cleaning															
Visual inspection of the water outlet (hose connection) for contamination															
Check the air filter for dirt and foreign bodies, clean or replace if necessary.															
Check the unit for damage (mains cable, housing, tank, fan wheel).															
Check fastening screws															
Test run															
Empty tank or check hose drainage															
Visual inspection of the sockets used.															
Testing the residual current device (RCD).															

1. Date: Signature	2. Date: Signature	3. Date: Signature	4. Date: Signature
5. Date: Signature	6. Date: Signature	7. Date: Signature	8. Date: Signature
9. Date: Signature	10. Date: Signature	11. Date: Signature	12. Date: Signature
13. Date: Signature	14. Date: Signature	15. Date: Signature	16. Date: Signature

Maintenance intervals:

Maintenance and Maintenance interval	before each commissioning	At Demand	At least all 2 weeks	At least all 4 weeks	At least all 6 months	At least annually
Check air inlet and air outlet and remove impurities. (Fig. 2, Fig1.)	X			X		
Exterior cleaning		X				X
Visual inspection of the water outlet (hose connection) for contamination		X				X
Check the air filter for dirt and foreign bodies, clean or replace if necessary.	X		X			
Check the unit for damage (mains cable, housing, tank, fan wheel).	X					
Test run						X
Empty tank or check hose drainage		X				
Visual inspection of the sockets used.	X					
Testing the residual current device (RCD).				X		

Check air inlet and air outlet

The unit draws in air from the rear (Fig. 2) and blows it out again from the side (Fig. 1). Make sure that the air inlet and air outlet are not blocked and check this each time you use the unit. Make sure that no objects or walls obstruct the air inlet or air outlet and observe the distance rules.

Check air filter:

This should be done every 2 weeks.

To do this, switch off the machine, disconnect the mains cable and remove the water tank. You can now pull the filter downwards out of the machine.

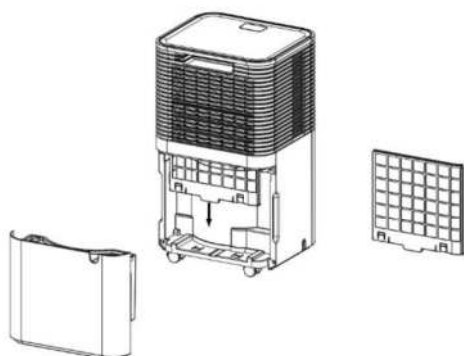

Rinse the filter with warm (maximum 40°C) clear water and let it dry. Make sure that the filter is not exposed to high temperatures and do not use any cleaning agents or other substances (such as petrol or alcohol). You can then reattach it to the unit.

Check the drainage hose:

Check the hose used for hose drainage regularly for blockages and damage. If the hose is blocked or damaged, replace it with a new one.

Storage of the dehumidifier

If the dehumidifier is not used for a longer period of time:

- 1) Switch off and unplug the unit.
- 2) Empty the water tank completely and make sure that there is no more water in the appliance.
- 3) Remove and clean the dust filters. Make sure that the filters are completely dry before reinserting them.
- 4) It is recommended to clean the unit completely when storing it for a longer period of time.
- 5) Store the dehumidifier in an upright position.
- 6) Store the dehumidifier in a safe, cool, dry and well-ventilated place indoors. Keep the unit away from direct sunlight, too high/low temperatures and high dust exposure. Make sure that the unit does not come into contact with corrosive gases or similar.

ATTENTION!

The evaporator inside the unit must be dried before the unit is packed. is used to prevent damage to the components and mould. Pull out the plug from the mains socket and place the unit in a dry, open place for a few days. place to dry it.

Frequently Asked Questions (FAQ)

You can find current operating instructions at: www.comedes.com

The unit will not switch on.

1. Is the unit plugged in correctly?
2. Is the water tank inserted correctly?
3. Is the tank "full" indicator lit?
4. has the fuse blown?
5. Is the room temperature above 35°C or below 5°C?
6. Is the timer function or the child lock activated?
7. if above is ok, then try again in 10 minutes.
8. if the unit still does not work, please contact service@comedes.com

The dehumidification capacity is too low.

1. Is the dust filter dirty?
2. is the air inlet or outlet blocked?
3. is the temperature or humidity too low?

The unit does not switch off in automatic mode.

1. are the windows and doors closed?
2. Does any appliance produce steam in this room?
3. is the room too big?

The unit is very loud.

1. Is the dust filter dirty?
2. is it standing on firm, level and suitable ground?
3. Does the unit touch the wall of the room?
4. for tiled floors, it is advisable to place a piece of carpet underneath.

The fuse keeps blowing.



The RCD (ground fault circuit interrupter) keeps tripping. Stop operation and contact us at: service@comedes.com

The mains cable or the plug becomes disproportionately warm.



Stop operating and contact us at: service@comedes.com

There are objects or water in the unit.

Stop operating and contact us at: service@comedes.com

Caution: Switch off and unplug the unit immediately and contact the customer service if anything unusual happens.

Error/Status messages

Error code	Possible cause	Possible effect	Solution
E2	Humidity sensor error	The unit switches off for safety reasons.	Contact us at service@comedes.com
LO	Humidity below 20%RH	The unit switches off for safety reasons.	Wait until the air humidity is above 20%RH.
HI	Humidity above 90%RH	The unit switches off for safety reasons.	Wait until the air humidity is below 90%RH.
CL	Room temperature below 5°C	The unit switches off for safety reasons.	Wait until the room temperature is above 5°C.
CH	Room temperature above 38°C	The unit switches off for safety reasons.	Wait until the room temperature is below 35°C.

Disposal instructions:

The release of refrigerant into the atmosphere is strictly prohibited!



This product must **not** be **disposed of in household waste**. This dehumidifier must be taken to a recycling point for electronic and electrical equipment. You can obtain more information about the relevant collection points from your local authority or Comedes GmbH.